

Interesting Evaluation in Control System Education: How to Select the Regulator Design Methods

Laszlo Keviczky

HUN-REN Institute for Computer Science and Control, Hungary

Csilla Bányász

HUN-REN Institute for Computer Science and Control, Hungary

Ruth Bars

Budapest University of Technology and Economics, Hungary

Abstract

All existing basic regulator design methods are summarized in this paper and compared concerning their usability and formal algebraic formulations. It is systematically proved that the best usable method is the Youla-parameterization based regulator design introduced by the authors. It is shown that the Youla regulator design is a very simple procedure, which is applicable for all kind of (minimum or non minimum phase) CT and DT processes. The computation of the regulator is very simple, requires only polynomial operations. For reasonable design goal this design results in an integrating regulator. This regulator ensures the theoretical best reachable closed-loop property of the control system. Youla controller design is superior to the other controller design methods, as the equations giving the relationships between the input and the output signals are linear in the parameter Q . For controlling systems with dead time this method gives straightforward solution for controller design. The applied method and procedure can be quite interesting in the education of the control system designers.

Keywords: Education, Regulator design, Control performance, Parameterization

To cite this article

Keviczky, L., Bányász, C., & Bars, R. (2024). Interesting Evaluation in Control System Education: How to Select the Regulator Design Methods. In C. Dignam & S. Alan (Eds.) *Proceedings of International Conference on Advances in Technology, Education and Science 2024*, (pp. 154-176). Alanya, Turkey. ARSTE Organization



This work is licensed under a Creative Commons Attribution-NonCommercial-ShareAlike 4.0 International License.

Introduction

The (Linear Time Invariant) *LTI* state-space equations of a system generally applied in systems and control theory

$$\begin{aligned} \frac{d\mathbf{x}(t)}{dt} &= \mathbf{A}\mathbf{x}(t) + \mathbf{b}u(t) \\ y(t) &= \mathbf{c}^T \mathbf{x}(t) + d_c u(t) \end{aligned} \quad (1)$$

Here u and y are the input and output signals of the process, and \mathbf{x} is the state vector. The matrices of the system are $\mathbf{A}, \mathbf{b}, \mathbf{c}^T, d_c$. Since this paper mainly treats *SISO* systems, in n -order case, matrix \mathbf{A} means a $(n \cdot n)$ square matrix, which is the so-called state matrix, \mathbf{b} is a column vector of $(n \cdot 1)$ size, \mathbf{c}^T is a row vector of $(1 \cdot n)$ size, and d_c is scalar.

The classical model of the dynamic *LTI* processes, the transfer function $P(s)$ is defined by the ratio of the LAPLACE transforms of the output and input signals, which can be easily derived from the state equation (1)

$$P(s) = \frac{Y(s)}{U(s)} = \mathbf{c}^T (s\mathbf{I} - \mathbf{A})^{-1} \mathbf{b} + d_c = \frac{\mathcal{B}(s)}{\mathcal{A}(s)} \quad (2)$$

where

$$\begin{aligned} \mathcal{A}(s) &= \det(s\mathbf{I} - \mathbf{A}) = s^n + a_1 s^{n-1} + \dots + a_n \\ \mathcal{B}(s) &= b_0 s^m + b_1 s^{m-1} + \dots + b_m \end{aligned} \quad (3)$$

The roots of equation $\mathcal{A}(s) = 0$ are called poles; the roots of $\mathcal{B}(s) = 0$ are called zeros. A *continuous-time* (CT) linear process is stable, if all roots of the polynomial $\mathcal{A}(s)$ are located on the left-hand side of the complex plane. Concerning the order of the polynomials $\mathcal{A}(s)$ and $\mathcal{B}(s)$ it should be noted that the number of the state variables is n , m is the order of the polynomial $\mathcal{B}(s)$, and for physically realizable systems the relation $m \leq n$ exists. The difference between the order of the numerator and denominator $p_T = n - m$ is called *pole excess*. If $p_T > 0$ then $P(s)$ is strictly proper, if $p_T = 0$ then the transfer function is proper. In the practice arbitrary relation $0 \leq p_T \leq n$ might occur.

Basic Regulator Design Methods

Control Loops with State Feedback

It was shown formerly how processes are represented in state-space. In many cases this kind of description is available only and the transfer function of the controlled system is unavailable. This partly explains why control design methodology directly based on state-space description has been evolved. Let us consider

$$\begin{aligned} \frac{dx}{dt} &= \dot{x} = Ax + bu \\ y &= c^T x \end{aligned} \quad (4)$$

which corresponds to (1) for the case of $d_c = 0$. This does not violate the generality, because it is very rare for the model to contain a proportional channel directly affecting the output. The block scheme of (4) and the classical state-feedback is shown in Fig. 1, where the thick lines present vector variables and r denotes the reference signal.

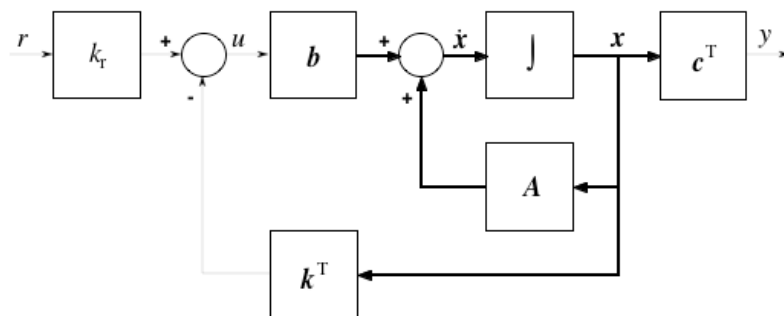

Figure 1: Linear regulator with state feedback

In the closed-loop the state vector is fed back with the linear proportional vector k^T according to the expression

$$u = k_r r - k^T x \quad (5)$$

Based on Fig. 1 the state equation of the complete closed system can be easily written as

$$\begin{aligned} \frac{dx}{dt} &= (A - bk^T)x + k_r br \\ y &= c^T x \end{aligned} \quad (6)$$

i.e., with the state feedback the dynamics represented by the original system matrix A is modified by the dyadic product bk^T to $(A - bk^T)$.

The transfer function of the closed-loop control is

$$\begin{aligned}
 T_{ry}(s) &= \frac{Y(s)}{R(s)} = \mathbf{c}^T (s\mathbf{I} - \mathbf{A} + \mathbf{b}\mathbf{k}^T)^{-1} \mathbf{b}k_r = \frac{\mathbf{c}^T (s\mathbf{I} - \mathbf{A})^{-1} \mathbf{b}k_r}{1 + \mathbf{k}^T (s\mathbf{I} - \mathbf{A})^{-1} \mathbf{b}} = \frac{k_r}{1 + \mathbf{k}^T (s\mathbf{I} - \mathbf{A})^{-1} \mathbf{b}} P(s) = \\
 &= \frac{k_r \mathcal{B}(s)}{\mathcal{A}(s) + \mathbf{k}^T \mathbf{\Psi}(s) \mathbf{b}}
 \end{aligned} \tag{7}$$

which derives from the comparison of equations valid for the LAPLACE transforms, $U(s) = k_r R(s) - \mathbf{k}^T \mathbf{X}(s)$ (see (6)) and $Y(s) = \mathbf{c}^T \mathbf{X}(s)$ (see (4)) using the matrix inversion lemma. Note that the state feedback leaves the zeros of the process untouched and only the poles of the closed-loop system can be designed by \mathbf{k}^T .

The so-called calibration factor k_r is introduced in order to make the gain of T_{ry} equal to unity ($T_{ry}(0) = 1$). The open loop is obviously not of type one, so it cannot provide zero error and unity static transfer gain. It can be ensured only if the condition

$$k_r = \frac{-1}{\mathbf{c}^T (\mathbf{A} - \mathbf{b}\mathbf{k}^T)^{-1} \mathbf{b}} = \frac{\mathbf{k}^T \mathbf{A}^{-1} \mathbf{b} - 1}{\mathbf{c}^T \mathbf{A}^{-1} \mathbf{b}} \tag{8}$$

is fulfilled. The above special control loop is called state feedback.

Pole placement by state feedback

The most natural design method of state feedback is the so-called pole placement. In this case the feedback vector \mathbf{k}^T needs to be chosen to make the characteristic equation of the closed-loop equal to the prescribed, so-called design polynomial $\mathcal{R}(s)$, i.e.,

$$\mathcal{R}(s) = s^n + r_1 s^{n-1} + \dots + r_{n-1} s + r_n = \det(s\mathbf{I} - \mathbf{A} + \mathbf{b}\mathbf{k}^T) = \mathcal{A}(s) + \mathbf{k}^T \mathbf{\Psi}(s) \mathbf{b} \tag{9}$$

The solution always exists if the process is controllable. (It is reasonable if the order of \mathcal{R} is equal to that of \mathcal{A}) In the exceptional case when the transfer function of the controlled system is known, the canonical state equations can be directly written. Based on the controllable canonical form the system matrices are

$$A_c = \begin{bmatrix} -a_1 & -a_2 & \square & -a_{n-1} & -a_n \\ 1 & 0 & \square & 0 & 0 \\ 0 & 1 & & 0 & 0 \\ \vdots & \vdots & \ddots & \vdots & \vdots \\ 0 & 0 & 0 & 1 & 0 \end{bmatrix} ; \quad c_c^T = [b_1, b_2, \square, b_n] ; \quad b_c = [1, 0, \square, 0]^T \quad (10)$$

Considering the special forms of A_c and b_c , it can be seen that the design equation (9) results in

$$k^T = k_c^T = [r_1 - a_1, r_2 - a_2, \square, r_n - a_n] \quad (11)$$

ensuring the characteristic equation ($\mathcal{R}(s) = 0$), i.e., the prescribed poles. The choice of the calibration factor can be determined by simple calculation

$$k_r = \frac{a_n + (r_n - a_n)}{b_n} = \frac{r_n}{b_n} \quad (12)$$

Based on equations (7), (8) and (9) it can be seen that in the case of state feedback pole placement the closed-loop transfer function results in

$$T_{ry}(s) = \frac{k_r \mathcal{B}(s)}{\mathcal{R}(s)} \quad (13)$$

The most common case of state feedback is when not the transfer function but the state-space form of the control system is given. It has to be observed that all controllable systems can be described in a controllable canonical form by using the transformation matrix $T_c = M_c^c (M_c)^{-1}$. This linear transformation also refers to the feedback vector

$$\begin{aligned} k^T &= k_c^T T_c = k_c^T M_c^c M_c^{-1} \\ k^T &= b_c^T M_c^{-1} \mathcal{R}(A) = [0, 0, \dots, 1] M_c^{-1} \mathcal{R}(A) \end{aligned} \quad (14)$$

The design relating to the controllable canonical form (10), together with the linear transformation relationship corresponding to the first row of the non-controllable form (14), is known as the BASS-GURA algorithm. The algorithm in the second row of (14) is called ACKERMANN method after its elaborator.

In the BASS-GURA algorithm, the inverse of the controllability matrix M_c needs to be determined by the general system matrices A and b on the one hand and the controllability matrix M_c^c of the controllable canonical form, on the other. Since this latter term depends only on the coefficients a_i in the denominator of the process transfer function, the denominator needs to be calculated: $A(s) = \det(sI - A)$. Since

$[0, 0, \dots, 1]M_c^{-1}$ is the last row of the inverse of the controllability matrix, and $\mathcal{R}(A)$ also need to be calculated; the ACKERMANN method does not need the calculation of $\mathcal{A}(s)$.

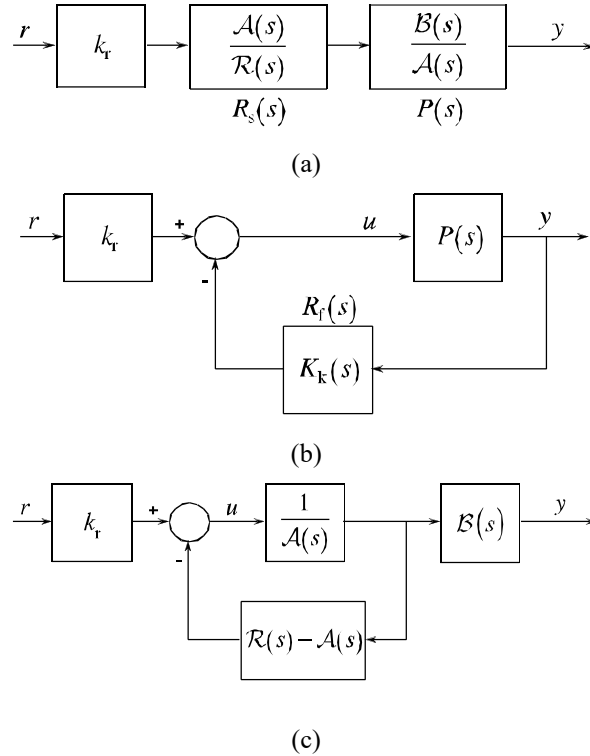

Figure 2: Equivalent schemes to the state feedback design using transfer functions and polynomials

It is worth mentioning that the state feedback formally corresponds to a conventional *PD* control and therefore over-actuating peaks are expected at the input of the process because the pole placement tries to make the process faster. In practice, however, the actuator usually limits the amplitude of the peaks, which needs to be taken into account during the design of the poles of the characteristic polynomial $\mathcal{R}(s)$.

It can be clearly seen that state feedback formally corresponds to a serial compensation $R_s = k_r \mathcal{A}(s) / \mathcal{R}(s)$ (Fig. 2a). The real operation and effect of the state feedback can be easily understood by the equivalent block schemes using the transfer functions shown in Fig. 2. The “regulator” $R_f(s)$ of the closed-loop is in the feedback line (Fig. 2b). The transfer function of the closed-loop is

$$T_{ry}(s) = \frac{k_r \mathcal{B}(s)}{\mathcal{R}(s)} = \frac{k_r \mathcal{B}(s)}{\mathcal{A}(s) + \mathcal{B}(s)} = \frac{k_r P(s)}{1 + K_k(s) P(s)} = \frac{k_r \mathcal{A}(s) \mathcal{B}(s)}{\mathcal{R}(s) \mathcal{A}(s)} = k_r R_s(s) P(s) \tag{15}$$

where

$$R_r = K_k(s) = \frac{\mathcal{K}(s)}{\mathcal{B}(s)} = \frac{\mathcal{R}(s) - \mathcal{A}(s)}{\mathcal{B}(s)} = \frac{\mathbf{k}^T (s\mathbf{I} - \mathbf{A})^{-1} \mathbf{b}}{\mathbf{c}^T (s\mathbf{I} - \mathbf{A})^{-1} \mathbf{b}} \quad (16)$$

and the calibration factor is

$$k_r = \frac{\mathbf{k}^T \mathbf{A}^{-1} \mathbf{b} - 1}{\mathbf{c}^T \mathbf{A}^{-1} \mathbf{b}} = \frac{1 + K_k(0)P(0)}{P(0)} \quad (17)$$

Given the block schemes of Fig. 2 it can be stated that the state feedback also stabilizes the unstable terms, since due to the effect of the polynomial $\mathcal{K}(s) = \mathcal{R}(s) - \mathcal{A}(s)$ there is a pole placement for any process, so with the stable $\mathcal{R}(s)$ the stabilization is fulfilled. The feedback polynomial $\mathcal{K}(s)$ formally corresponds to \mathbf{k}^T . The fact that the numerator $\mathcal{B}(s)$ of the process is present in the denominator of $K_k(s)$ needs special consideration. The regulator can be applied only for minimum phase (inverse stable) processes, where the roots of $\mathcal{B}(s)$ are stable. As a consequence of this special character of the state feedback, however, here $\mathcal{B}(s)$ is not substituted by its model $\hat{\mathcal{B}}(s)$, but the method itself realizes the exact $1/\mathcal{B}(s)$.

Pole Placement with Pole Cancellation

Consider the closed control system shown in Fig. 3, where the regulator $C = \mathcal{A}/\mathcal{X}$ is used to place the poles of the closed control system according to the characteristic equation $\mathcal{R} = 0$, (\mathcal{R} is the design polynomial) by the cancellation of the process poles. To do this, \mathcal{X} needs to be expressed by the equation $\mathcal{R} = \mathcal{X} + \mathcal{B}$. The complementary sensitivity function of the closed-loop is

$$T = \frac{\frac{\mathcal{A} \mathcal{B}}{\mathcal{X} \mathcal{A}}}{1 + \frac{\mathcal{A} \mathcal{B}}{\mathcal{X} \mathcal{A}}} = \frac{\mathcal{A} \mathcal{B}}{\mathcal{A} \mathcal{X} + \mathcal{A} \mathcal{B}} = \frac{\mathcal{B}}{\mathcal{X} + \mathcal{B}} = \frac{\mathcal{B}}{\mathcal{R}} \quad (18)$$

The regulator is

$$C = \frac{\mathcal{A}}{\mathcal{X}} = \frac{\mathcal{A}}{\mathcal{R} - \mathcal{B}} = \frac{\frac{\mathcal{B}}{\mathcal{R}} \mathcal{A}}{1 - \frac{\mathcal{B}}{\mathcal{R}}} = \frac{R_r}{1 - R_r} P^{-1} \quad (19)$$

and actually corresponds to an ideal YOULA regulator (see later) with reference model $R_r = R_n = \mathcal{B}/\mathcal{R}$. This regulator places the poles in \mathcal{R} and leaves the zeros in \mathcal{B} untouched, if they are inverse stable.

A usual pole canceling regulator is the $PI(D)$ regulator, where in case of PI regulator the transfer function of the regulator is $C(s) = k_c \frac{1+sT_I}{sT_I}$, and in case of PID regulator $C(s) = k_c \frac{1+sT_I}{sT_I} \frac{1+sT_D}{1+sT'_D}$, where $T_D > T'_D$.

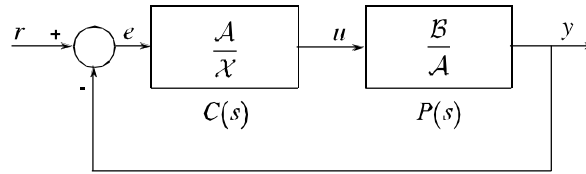

Figure 3: Pole canceling regulator

A special case of pole cancellation is the use of the $PI(D)$ controllers where generally not the whole denominator of the process is cancelled. PI controller cancels the biggest time constant term of the process and in its denominator $X(s)$ introduces an integrating effect. PID controller cancels the two biggest time constant terms of the process and introduces in its denominator an integrating effect and a smaller time constant. The gain k_c of the controller is designed to ensure stability and good phase margin for the control system.

Pole Placement with Feedback Regulator

An other solution when the regulator is put in the feedback is shown in Fig. 4.

Now the task is again to place the poles of the closed system according to the equation $\mathcal{R} = 0$ (\mathcal{R} is the design polynomial). To do this, \mathcal{K} needs to be determined from the equation $\mathcal{R} = \mathcal{K} + \mathcal{A}$. The complementary sensitivity function of the closed system is

$$T = \frac{\frac{B}{A}}{1 + \frac{\mathcal{K} B}{B A}} = \frac{B}{A + \mathcal{K}} = \frac{B}{\mathcal{R}} \tag{20}$$

and thus this regulator places the poles in \mathcal{R} and leaves the zeros in B untouched, if they are inverse stable.

The characteristic equation of the closed system has the form $\mathcal{R} = 0$ and it does not depend on the unstable property of the process.

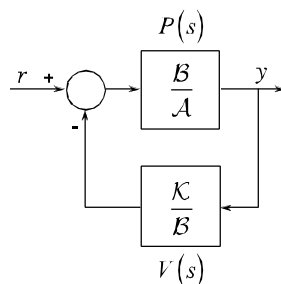

Figure 4: Regulator in the feedback

The block diagram in Fig. 5. can be redrawn as Fig. 2c. (The state feedback methods are discussed in detail in Section 2.1, and the same control principle is represented in Fig. 2c among the schemes showing the equivalent transfer function representations for state feedback.)

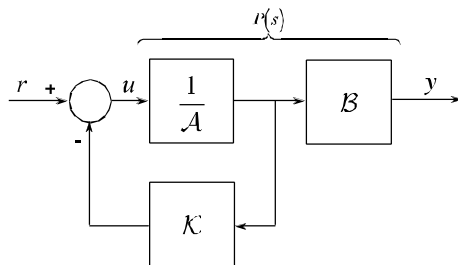

Figure 5: The regulator feeds back the internal signal of the process

Pole Placement with Characteristic Polynomial Design

The characteristic polynomial \mathcal{R} of the closed-loop control can be directly designed by algebraic methods. In Fig. 6 the regulator $C = \mathcal{Y}/\mathcal{X}$ is the quotient of two polynomials. Under certain conditions, the (Diophantine Equation) $DE \mathcal{A}\mathcal{X} + \mathcal{B}\mathcal{Y} = \mathcal{R}$ can be solved for \mathcal{X} and \mathcal{Y} . Thus from the characteristic equation $\mathcal{R} = 0$ the regulator can be directly determined.

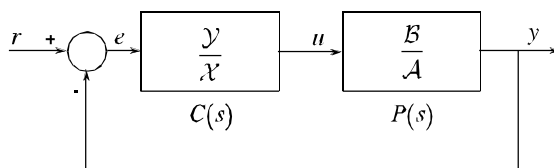

Figure 6: Direct control design on the basis of the characteristic polynomial

The complementary sensitivity function of the closed system is

$$T = \frac{\frac{\mathcal{Y}}{\mathcal{X}} \frac{\mathcal{B}}{\mathcal{A}}}{1 + \frac{\mathcal{Y}}{\mathcal{X}} \frac{\mathcal{B}}{\mathcal{A}}} = \frac{\mathcal{B}\mathcal{Y}}{\mathcal{A}\mathcal{X} + \mathcal{B}\mathcal{Y}} = \frac{\mathcal{B}\mathcal{Y}}{\mathcal{R}} \tag{21}$$

and thus this regulator also places the poles in \mathcal{R} and leaves the zeros in \mathcal{B} untouched, but in the nominator \mathcal{Y} appears, which depends on the desired properties and also on DE .

Thus the characteristic equation of the closed system has the form $\mathcal{R} = 0$ and it does not depend on the unstable character of the process.

Regulators Based on YOULA Parameterization

The YOULA parameter, as a matter of fact, is a stable (by definition), regular transfer function

$$Q(s) = \frac{C(s)}{1 + C(s)P(s)} \text{ or shortly } Q = \frac{C}{1 + CP} \tag{22}$$

where $C(s)$ is a stabilizing regulator, and $P(s)$ is the transfer function of the stable process.

It follows from the definition of the YOULA parameter that the structure of the realizable and stabilizing regulator in the YOULA-parameterized (sometimes called Q -parameterized) control loop is fixed:

$$C(s) = \frac{Q(s)}{1 - Q(s)P(s)} \text{ or shortly } C = \frac{Q}{1 - QP} \tag{23}$$

The sensitivity and complementary sensitivity functions of the closed control system are linear in Q and are calculated by (24). It is interesting to observe that the YP regulator of (23) can be realized by a simple control loop with positive feedback as shown in Fig. 7.

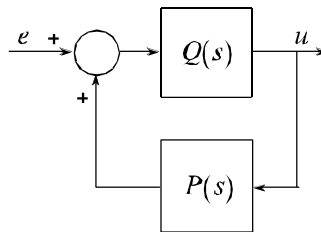

Figure 7: Realization of a YP regulator

A YOULA-parameterized (YP) closed-loop is shown in Fig. 8.

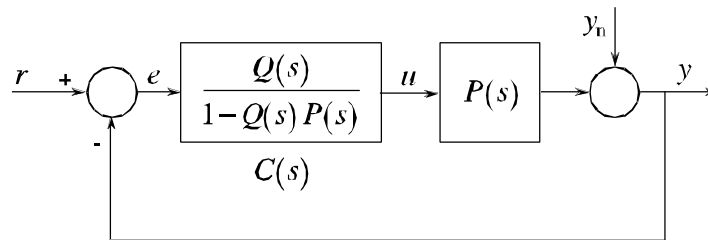

Figure 8: YOULA-parametrized closed-loop

The All-Realizable-Stabilizing (ARS) regulator has the form of (23).

The closed-loop transfer function or Complementary Sensitivity Function (CFS) is

$$T = \frac{CP}{1 + CP} = QP \tag{24}$$

which is linear in the YOULA parameter Q . It is well known that the YP regulator corresponds to the classical

IMC (Internal Model Control) structure.

The relationships between the most important signals of the closed system can be obtained with simple calculations

$$\begin{aligned}
 u &= Qr - Qy_n \\
 e &= (1 - QP)r - (1 - QP)y_n = Sr - Sy_n \\
 y &= QPr + (1 - QP)y_n = Tr + Sy_n
 \end{aligned}
 \tag{25}$$

The effect of r and y_n on u and e is completely symmetrical (not considering the sign). Thus the input of the process depends only on the external signals and $Q(s)$.

The IMC form of the control system is shown in Fig.9. Reference signal filter and disturbance filter can be introduced to make different transfer properties for reference signal tracking and disturbance rejection (Fig. 10, Fig.11).

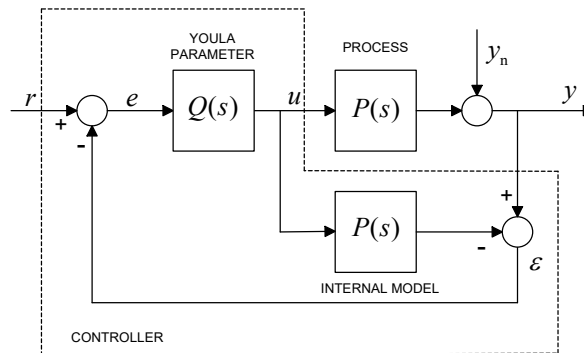

Figure 9: IMC form of YOULA parameterization

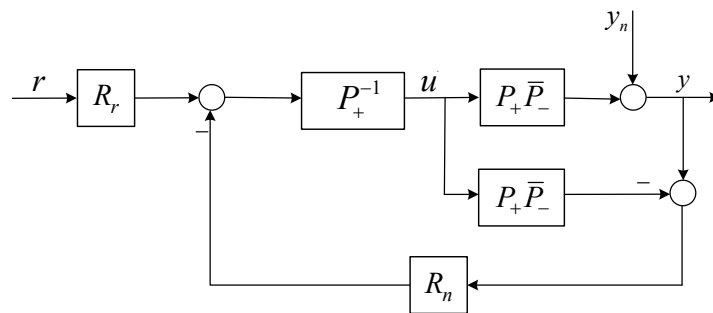

Figure 10: IMC form of YOULA parameterization with reference and disturbance filters

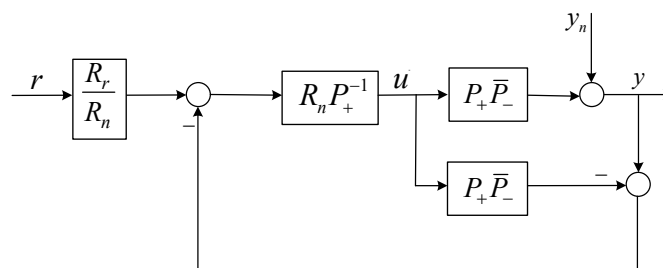

Figure 11: IMC form of YOULA parameterization with filters

From the equation (24) it can be seen that the YOULA parameterization has the transfer function QP_r concerning the reference signal tracking. If the KB parameterization is introduced as shown in figure Fig. 8, then the YOULA parameterization can be extended for $TDOF$ control systems. To do this, let us simply apply a parameter Q_r for the design of the tracking properties, and connect it in serial to the KB -parameterized loop, so the block diagram of Fig. 12 is obtained.

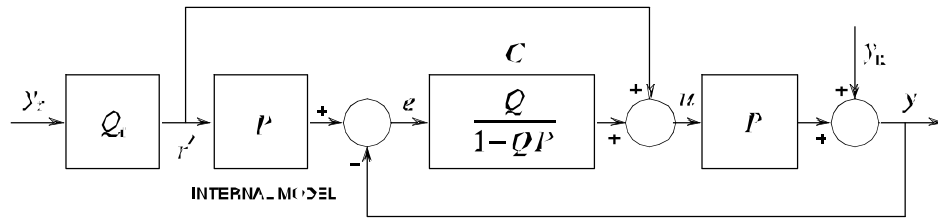

Figure 12: Two-degree-of-freedom version of the YP control loop

The overall transfer characteristics for this system are

$$\begin{aligned}
 u &= Q_r y_r - Q y_n \\
 e &= (1 - Q_r P) y_r - (1 - QP) y_n = (1 - T_r) y_r - S y_n \quad (26) \\
 y &= Q_r P y_r + (1 - QP) y_n = T_r y_r + (1 - T) y_n = T_r y_r + S y_n
 \end{aligned}$$

where the tracking properties can be designed by choosing Q_r in $T_r = Q_r P$, and the noise rejection properties by choosing Q in $T = QP$. These two properties can be handled separately. The reference signal of the whole system is denoted by y_r . The conditions for Q_r are the same as for Q . The meaning of T_r is analogous to the meaning of the complementary sensitivity function T of the one-degree-of-freedom control loop for tracking.

Comparison of the Previously Discussed Design Methods

Control loops with state feedback

The most important advantage of the state feedback regulator is that the calculation of the feedback vector is very simple. The most important disadvantage is that the internal state variables, necessary for the feedback are usually not available in the practical tasks. This is why the observer topology is generally necessary to this method. Unfortunately, this topology is not so simple to compute. Another important disadvantage is that this regulator assigns the pole of the closed-loop system, unfortunately it leaves the numerator of the process untouched in T . It is important to know that from the methods discussed in this paper this is the only method which is applicable for unstable processes.

Pole placement with pole cancellation

The most important advantage of this method is that it is very simple to calculate the regulator. The disadvantage is that this regulator assigns the poles of the closed-loop system, unfortunately it also leaves the numerator of the process untouched in T .

Pole placement with feedback regulator

This method practically can be evaluated on the similar way as the previous method. Unfortunately the most important disadvantage is that in a practical task it is very rare that the regulator is in the feedback line.

Pole placement with characteristic polynomial design

This method is a little bit more complex than the pole cancellation method, because the calculation of the regulator needs the solution of a DE . The disadvantage is that this regulator assigns the pole of the closed-loop system, unfortunately it also leaves the numerator of the process untouched in T and puts another polynomial in the numerator of T . This polynomial comes from the solution of the DE , so it is not easy to design.

Regulators based on YOULA parameterization

This method is the simplest, because it needs only basic polynomial operations to calculate the regulator. A further advantage is that the result of the design is the best reachable T even for invariant process zeros, too.

Except the state feedback regulator, the other methods are applicable only for stable processes.

Computation of the Optimal YOULA Regulator

Let us assume the transfer function of the process in the following factorized form

$$P(s) = P_+(s) \bar{P}_-(s) = P_+(s) P_-(s) e^{-sT_d} \quad (27)$$

or shortly

$$P = P_+ \bar{P}_- = P_+ P_- e^{-sT_d} \quad (28)$$

where P_+ is stable, and its inverse is also stable (*Inverse Stable: IS*) and realizable (*ISR*). The inverse of \bar{P}_- is unstable (*Inverse Unstable: IU*) and not realizable (*Non Realizable: NR*), i.e., (*IUNR*). P_- is inverse unstable

(IU). Here, in general, the inverse of the dead-time part e^{-sT_d} is not realizable, because it would be an ideal predictor.

In polynomial form a delay free process is given by

$$P(s) = \frac{\mathcal{B}(s)}{\mathcal{A}(s)} = \frac{\mathcal{B}_+(s)\mathcal{B}_-(s)}{\mathcal{A}(s)} \tag{29}$$

where $\mathcal{B}_+(s)$ and $\mathcal{B}_-(s)$ contain the inverse stable and inverse unstable zeros, respectively.

If the reference model, formulating our design goal is

$$R_n(s) = \frac{\mathcal{B}_n(s)}{\mathcal{A}_n(s)} \tag{30}$$

then the optimal YOULA parameter is

$$Q(s) = R_n(s)\mathcal{B}_+^{-1}(s) \tag{31}$$

Using this parameterization the optimal YOULA regulator can be calculated as

$$C(s) = \frac{Q(s)}{1-Q(s)P(s)} = \frac{R_n(s)\mathcal{B}_+^{-1}(s)\mathcal{A}(s)}{\mathcal{A}(s) - R_n(s)\mathcal{B}_+^{-1}(s)\mathcal{B}_+(s)\mathcal{B}_-(s)} = \frac{\mathcal{B}_n(s)\mathcal{A}(s)}{\mathcal{B}_+(s)[\mathcal{A}_n(s)\mathcal{A}(s) - \mathcal{B}_n(s)\mathcal{B}_-(s)]} \tag{32}$$

The transfer function of the closed-loop system is

$$T(s) = R_n(s)\mathcal{B}_-(s) = \frac{\mathcal{B}_n(s)}{\mathcal{A}_n(s)}\mathcal{B}_-(s) \tag{33}$$

which is the best reachable result for the case of inverse unstable zeros. This result explains the name: “uncancellable” for the inverse unstable factors of the numerator of the process.

For the two-degree-of-freedom version of the YOULA regulator (see Fig. 9) an additional reference model

$$R_r(s) = \frac{\mathcal{B}_r(s)}{\mathcal{A}_r(s)} \tag{34}$$

must also be calculated.

It can be well seen in this section that the computation of the YOULA regulator requires only very simple polynomial operations (additions and multiplications).

Examples

Example 1. Let the CT process be given by a non-minimum phase transfer function

$$P(s) = \frac{(1+s\tau_1)(1-s\tau_2)}{(1+sT_1)(1+sT_2)(1+sT_3)} \quad (35)$$

where $T_1 = 10\text{sec}$; $T_2 = 5\text{sec}$; $T_3 = 2\text{sec}$; $\tau_1 = 6\text{sec}$ and $\tau_2 = 4\text{sec}$, where $\mathcal{B}_+ = (1+s\tau_1)$ and $\mathcal{B}_- = (1-s\tau_2)$

The selected reference model is

$$R_n(s) = \frac{\mathcal{B}_n(s)}{\mathcal{A}_n(s)} = \frac{1+s\tau_{n1}}{1+sT_{n1}} = \frac{1}{1+sT_{n1}} \quad (36)$$

where $T_{n1} = 5\text{sec}$; $\tau_{n1} = 0$.

The optimal YOULA regulator can be calculated as

$$C(s) = \frac{\mathcal{B}_n(s)\mathcal{A}(s)}{\mathcal{B}_+(s)[\mathcal{A}_n(s)\mathcal{A}(s) - \mathcal{B}_n(s)\mathcal{B}_-(s)]} = \frac{(1+sT_1)(1+sT_2)(1+sT_3)}{(1+s\tau_1)[(1+sT_{n1})(1+sT_1)(1+sT_2)(1+sT_3) - (1-s\tau_2)]} \quad (37)$$

Using the numerical values the regulator is

$$C(s) = \frac{1+17s+80s^2+100s^3}{s(1+6s)(1+2.273s+4.454s^2)} \quad (38)$$

The overall transfer function of the closed-loop system is

$$T(s) = R_n(s)\mathcal{B}_-(s) = \frac{1-s\tau_2}{1+sT_{n1}} = \frac{1-4s}{1+5s} \quad (39)$$

Because usually the reference model has unity gain, i.e.

$$\mathcal{B}_n(0) = \mathcal{A}_n(0) \quad (40)$$

it follows, that $T(0) = 1$ has also unity gain.

The usual normalization of the process polynomial means that $\mathcal{A}(0) = 1$ and $\mathcal{B}_-(0) = 1$ (while $\mathcal{B}_+(0) \neq 1$) it can be easily checked that the YOUCLA regulator is always an integrating regulator for (40).

Example.2. The CT process is now given by the transfer function

$$P(s) = \frac{6}{(s+1)(s+2)(s+3)} \tag{41}$$

Let us design regulators with all the discussed methods and compare their behavior.

Pole placement with state feedback.

Let the prescribed poles of the closed loop system obtained by state feedback be: $-6; -3+4 \cdot i; -3-4 \cdot i$.

Thus the prescribed characteristic polynomial is

$$R(s) = s^3 + 12s^2 + 61s + 150 \tag{42}$$

The controllable canonical form of the state equation is:

$$A = \begin{bmatrix} -6 & -11 & -6 \\ 1 & 0 & 0 \\ 0 & 1 & 0 \end{bmatrix}; \quad b = \begin{bmatrix} 1 \\ 0 \\ 0 \end{bmatrix} \tag{43}$$

$$c = \begin{bmatrix} 0 & 0 & 6 \end{bmatrix}; \quad d = 0$$

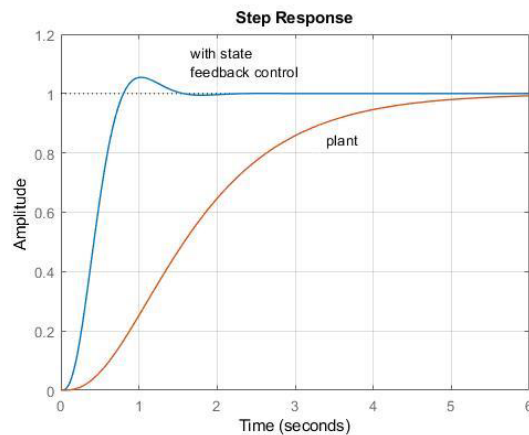

Figure 13. Step response with state feedback control

The state feedback vector calculated according to (11) is

$$k = \begin{bmatrix} 6 & 50 & 144 \end{bmatrix}^T \tag{44}$$

and the value of the calibration factor calculated according to (8) is 25. The calculations can be also supported by MATLAB control toolbox. The step response of the plant and of the controlled system is shown in Fig. 13.

Pole placement with pole cancellation

According to (19)

$$C = \frac{A}{\mathcal{X}} = \frac{A}{\mathcal{R}-\mathcal{B}} = \frac{\frac{B}{\mathcal{R}}}{1-\frac{B}{\mathcal{R}}} \frac{A}{B} = \frac{R_r}{1-R_r} P^{-1} \quad (45)$$

In order to eliminate steady state error let us divide the characteristic polynomial R by a factor which ensures that its constant term will be equal to $B(0)$, so the controller will be of integral type.

$$R_m(s) = (s^3 + 12s^2 + 61s + 150) / 25 \quad (46)$$

So the transfer function of the controller is

$$C(s) = \frac{s^3 + 6s^2 + 11s + 6}{0.04s^3 + 0.48s^2 + 2.44s} \quad (47)$$

The step response is shown in Fig. 14 and the control signal is given in Fig. 15.

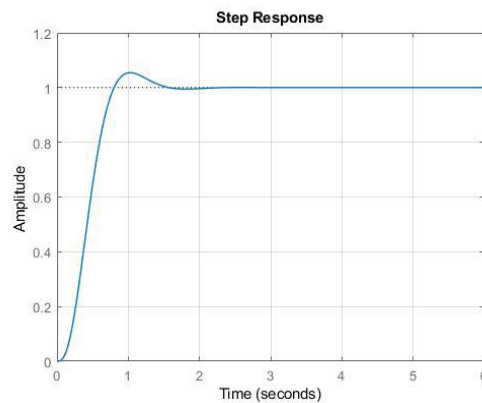

Figure 14. Step response with pole cancellation

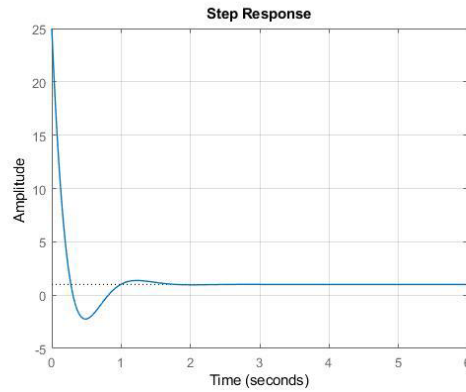

Figure 15. Control signal in case of pole cancellation

It is seen that over-excitation in the control signal ensures acceleration of the output signal. Of course there is a practical limit of the control signal provided by the actuator.

Pole placement with feedback regulator

In this solution the overall transfer function is given by (20). Again, to ensure unity transfer gain the characteristic polynomial R should be normalized to have the same constant term as $B(0)$.

YOULA parameterized regulator design

Let the transfer function of the reference signal filter be

$$R_r(s) = \frac{150}{s^3 + 12s^2 + 61s + 150} \tag{48}$$

which ensures the poles of the characteristic equation as shown in point *a.*/.

Let the transfer function of the noise filter be

$$R_n(s) = \frac{64}{(s+4)^3} = \frac{64}{s^3 + 12s^2 + 48s + 64} \tag{49}$$

The YOULA parameter is

$$Q(s) = R_n(s)P^{-1}(s) = \frac{64(s+1)(s+2)(s+3)}{6s^3 + 12s^2 + 48s + 64} \tag{50}$$

The output signal as response to a unit step reference signal and the output signal as a response to unit step disturbance is shown in Fig. 16.

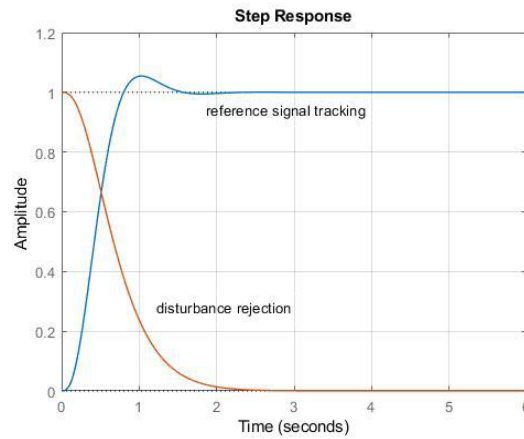

Figure 16: Unit step reference signal tracking and disturbance rejection of the YOULA parameterized controller

Example 3. Let the CT process be given by a non-minimum phase transfer function

$$P(s) = \frac{\mathcal{B}(s)}{\mathcal{A}(s)} = \frac{(1+s\tau_1)(1-s\tau_2)}{(1+sT_1)(1+sT_2)(1+sT_3)} = \frac{\mathcal{B}_+(s)\mathcal{B}_-(s)}{\mathcal{A}(s)} = P_+(s)\mathcal{B}_-(s) \quad (51)$$

where $T_1 = 10\text{sec}$; $T_2 = 5\text{sec}$; $T_3 = 2\text{sec}$; $\tau_1 = 6\text{sec}$ and $\tau_2 = 4\text{sec}$, where $\mathcal{B}_+ = (1+s\tau_1)$ and $\mathcal{B}_- = (1-s\tau_2)$

Furthermore $P_+(s) = \frac{\mathcal{B}_+(s)}{\mathcal{A}(s)}$ and $Q(s) = R_n(s)P_+^{-1}(s)$ should be proper.

The selected reference model is

$$R_n(s) = \frac{\mathcal{B}_n(s)}{\mathcal{A}_n(s)} = \frac{1}{(1+sT_{n1})(1+sT_{n2})} = \frac{1}{(1+2s)(1+s)} \quad (52)$$

where $T_{n1} = 2\text{sec}$ and $T_{n2} = 1\text{sec}$. Then

$$Q(s) = \frac{1}{(1+2s)(1+s)} \frac{(1+10s)(1+5s)(1+2s)}{1+6s} = \frac{(1+10s)(1+5s)}{(1+s)(1+6s)} \quad (53)$$

and

$$C(s) = 0.1428 \frac{(1+10s)(1+5s)(1+2s)}{s(1+0.2857)(1+6s)} \quad (54)$$

$$T(s) = \frac{1-4s}{(1+s)(1+2s)} \quad (55)$$

The step response of the plant and of the controlled system is shown in Fig.17.

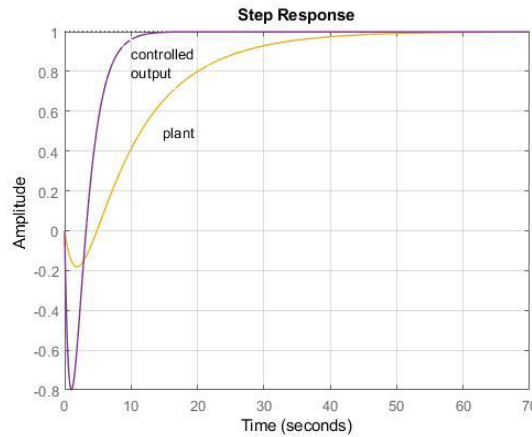

Figure 17: YOULA control of a non-minimum phase plant

It is seen that the output is settled faster, but in the first instants the output goes to negative values. With reference signal filter the output can be further modified.

Because usually the reference model has unity gain, i.e.

$$B_n(0) = A_n(0) \tag{56}$$

it follows, that $T(0) = 1$ has also unity gain.

The usual normalization of the process polynomial means that $A(0) = 1$ and $B_-(0) = 1$ (while $B_+(0) \neq 1$) it can be easily checked that the YOULA regulator is always an integrating regulator for (55).

Example 4 Investigate now a discrete-time (DT) case, when the pulse transfer function of the process is a second order system

$$G(z) = \frac{-0.32(z - 1.25)}{(z - 0.8)(z - 0.6)} = G_-(z)G_+(z) \tag{57}$$

where $G_-(z) = \frac{z - 1.25}{-0.25}$ is the non-cancellable part containing a zero outside of the unit circle and

$$G_+(z) = \frac{-0.25 \cdot -0.32}{(z - 0.8)(z - 0.6)} = \frac{0.08}{(z - 0.8)(z - 0.6)} \tag{58}$$

is the cancellable part of the pulse transfer function.

The noise reference model is

$$R_n(z) = \frac{0.6}{z - 0.4} \quad (59)$$

The relationships given for continuous systems are valid for the pulse transfer functions of the discrete systems as well. The YOULA parameter is

$$Q(z) = R_n(z)G_+^{-1}(z) = \frac{0.6}{z - 0.4} \frac{(z - 0.8)(z - 0.6)}{0.08} = 7.5 \frac{(z - 0.8)(z - 0.6)}{z - 0.4} \quad (60)$$

and the optimal YOULA regulator can be computed now as

$$C(z) = \frac{Q(z)}{1 - Q(z)G(z)} = \frac{2.2059(z - 0.8)(z - 0.6)}{z - 1} \quad (61)$$

Fig. 18 shows the unit step response of the plant and of the controlled system.

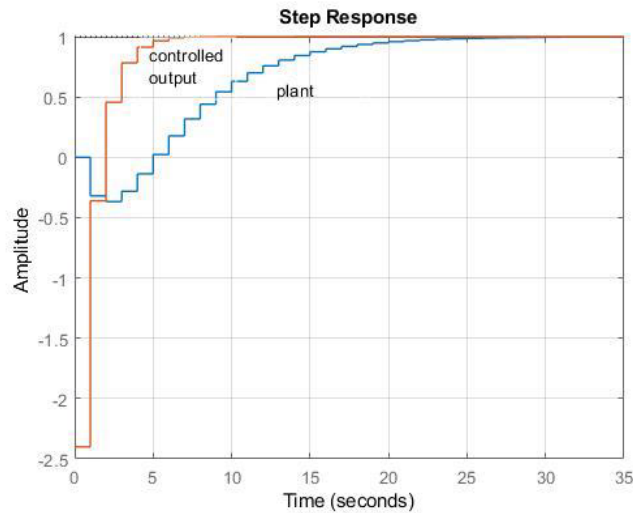

Figure 18. Unit step responses of the plant and the controlled system

Example.5 Discrete YOULA controller of a system with dead time

The transfer function of the continuous process is

$$P(s) = \frac{1}{(1 + 5s)(1 + 10s)} e^{-30s} \quad (62)$$

The sampling time is $T_s = 1$ sec. The reference signal and disturbance filters are obtained by sampling the systems given by transfer functions

$$R_r(s) = \frac{1}{1 + 2s} \quad \text{and} \quad R_n(s) = \frac{1}{1 + 4s} \quad (63)$$

Design the YOULA controller and give the output and control signals in the sampling points.

The pulse transfer function of the process $P(s)$ is:

$$G(z) = \frac{0.0090559(z + 0.9048)}{(z - 0.9048)(z - 0.8187)} z^{-30} \quad (64)$$

Let us separate it to the cancellable $G_+(z)$ and the non-cancellable $G_-(z)$ factors. $G_-(z)$ should be normalized for transfer gain 1.

The pulse transfer functions are given with the shift operator z^{-1} :

$$G_-(z) = \frac{1 + 0.9048z^{-1}}{1.9048} \quad (65)$$

$$G_+(z) = \frac{0.0090559 \cdot 1.9048z^{-1}}{(1 - 0.9048z^{-1})(1 - 0.8187z^{-1})}$$

The pulse transfer functions of the filters:

$$R_r(z) = \frac{0.39347z^{-1}}{1 - 0.6065z^{-1}} \quad \text{and} \quad R_n(z) = \frac{0.2212z^{-1}}{1 - 0.7788z^{-1}} \quad (66)$$

The YOULA parameter is given by

$$Q(z) = \frac{R_n}{G_+} = 12.82 \frac{(1 - 0.9048z^{-1})(1 - 0.8187z^{-1})}{1 - 0.7788z^{-1}} \quad (67)$$

Conclusion

It was shown that the YOULA regulator design is a very simple procedure, which is applicable for all kind of (minimum or non minimum phase) CT and DT processes. The computation of the regulator is very simple, requires only polynomial operations.

For reasonable design goal this design results in an integrating regulator. This regulator ensures the theoretical best reachable closed-loop property of the control system.

YOULA controller design is superior to the other controller design methods, as the equations giving the relationships between the input and the output signals are linear in the parameter Q . For controlling systems with dead time this method gives straightforward solution for controller design. The applied methods and procedures are very useful in the education of the control system designers.

References

- Åström, K.J. and B. Wittenmark (1984). Computer Controlled Systems. Prentice-Hall, p. 430.
- Goodwin, G.C., Graebe S.F. and Salgado M.E. (2001). Control System Design. Prentice-Hall, p. 908.
- Horowitz, I.M. (1963). Synthesis of Feedback Systems, Academic Press, New York.
- Keviczky, L. (1995). Combined identification and control: another way. (Invited plenary paper.) *5th IFAC Symp. on Adaptive Control and Signal Processing, ACASP'95*, 13-30, Budapest, Hungary.
- Keviczky, L. and Cs. Bányász (1999). Optimality of two-degree of freedom controllers in \mathcal{H}_2 - and \mathcal{H}_∞ -norm space, their robustness and minimal sensitivity. *14th IFAC World Congress*, F, 331-336, Beijing, PRC.
- Keviczky, L. and Cs. Bányász (2015). Two-Degree-of-Freedom Control Systems (The Youla Parameterization Approach), Elsevier, Academic Press, p. 512.
- Keviczky, L., R. Bars, J. Hetthéssy and Cs. Bányász (2018). Control Engineering. Springer.
- Keviczky, L., R. Bars, J. Hetthéssy and Cs. Bányász (2018). Control Engineering: MATLAB Exercises, Springer.
- Maciejowski, J.M. (1989). Multivariable Feedback Design, Addison Wesley, p. 424.
- Youla, D.C., Bongiorno, J.J. and C. N. Lu (1974). Single-loop feedback stabilization of linear multivariable dynamical plants, *Automatica*, Vol. 10, 2, pp. 159-173.
- Youla, D.C. and J.J. Bongiorno, Jr. (1985). A feedback theory of two-degree-of-freedom optimal Wiener-Hopf design," *IEEE Trans. Auto. Control*, vol. AC-30, No. 7, pp. 652-665.

Author Information

László Keviczky

<https://orcid.org/0000-0002-7323-6427>
 HUN-REN Institute for Computer Science and
 Control, Hungarian Research Network
 H-1111 Budapest, Kende u 13-17.
 Hungary

Csilla Bányász

<https://orcid.org/0000-0002-3623-9852>
 HUN-REN Institute for Computer Science and
 Control, Hungarian Research Network
 H-1111 Budapest, Kende u 13-17.
 Hungary

Ruth Bars

<https://orcid.org/0000-0002-3467-0235>
 Department of Automation and Applied Informatics
 Budapest University of Technology and Economics
 H-1117 Budapest, Magyar tudósok krt. 2., Building
 Q.
 Hungary
